

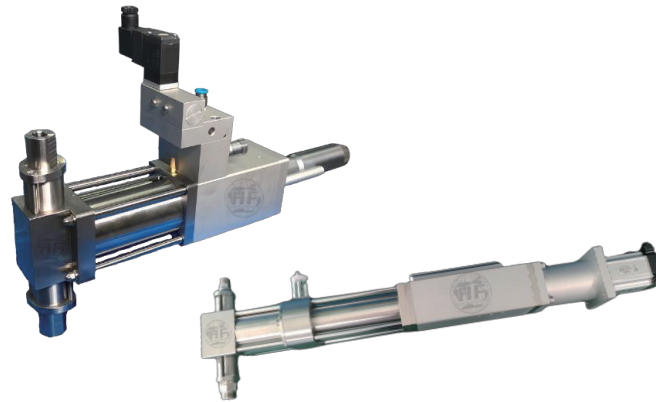

<b>Dispense Volume</b> 0-250ml
<b>Viscosity</b> Low to Medium (<20,000 cps)
<b>No Particles</b>
<b>Applications</b>
For the Cosmetics, Technical and Chemical Industries but also can be used in the Food and Pharmaceutical Industries.



## Details

Electric or Pneumatic Start Signal

Precision Volumetric Adjustment

Programmable Servo Speed Profiling

Fine Adjustment Speed Control

Precision Servo Drive and Motor

Internal Full Stroke Sensor

Precision Pneumatic Drive

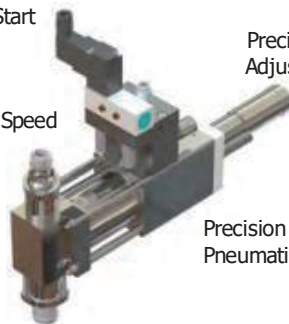

316 SS Construction - Other Materials of Construction Available

High Accuracy  
+/- 0.5% or Better

Model		Plunger Diameter		Stroke	Maximum Dispensing Volume (cc)	Cycle Speed (cpm) <sup>C</sup>	Air Consumption scfm (l/min) <sup>C</sup>	Weight lbs (kg) <sup>C</sup>
Pneumatic	Servo	Inch	mm	Inch (mm)				
4H1-C-10	4S1-C-10	7/8	22.23	1.00 (25.4)	9.9	0-180 <sup>A</sup>	3.64 (103) <sup>B</sup>	13.75 (6.2)
4H1-C-30	4S1-C-30	1-5/8	41.28		34.0			
4H1-C-60	4S1-C-60	2-1/8	53.98		58.0			
4H2-C-20	4S2-C-20	7/8	22.23	2.00 (50.8)	20.0	0-150 <sup>A</sup>	7.27 (205.8) <sup>B</sup>	15.25 (6.9)
4H2-C-65	4S2-C-65	1-5/8	41.28		68.0			
4H2-C-110	4S2-C-110	2-1/8	53.98		116.0			
4H3-C-30	4S3-C-30	7/8	22.23	3.00 (76.2)	30.0	0-120 <sup>A</sup>	10.91 (308.9) <sup>B</sup>	16.75 (7.6)
4H3-C-100	4S3-C-100	1-5/8	41.28		102.0			
4H3-C-170	4S3-C-170	2-1/8	53.98		174.0			
4H4.5-C-150	4S4.5-C-150	1-5/8	41.28	4.50 (114.3)	153.0	0-90 <sup>A</sup>	16.36 (463.3) <sup>B</sup>	19.0 (8.6)
4H4.5-C-260	4S4.5-C-260	2-1/8	53.98		261.0			

<sup>A</sup> Maximum cycle rate is application dependant

<sup>B</sup> Calculated at full stroke at 100cpm, 75 PSI (5 Bar)

<sup>C</sup> Pneumatic Drive Only



Fittings		
Type	Size	
	Inlet	Outlet
Sanitary	1/2 - 3/4	1/2 - 3/4
Swage	1/8 - 1/2	1/8 - 3/8
Tube	1/8 - 1/2	1/8 - 3/8
Hose	1/2 - 3/4	1/2 - 5/8

O-rings & U-cups	
O-rings	U-cup Seals
Viton	Teflon
EP	UHMW
Silicon	
Buna	
Perfluor (Kalrez®)	

Units: Inches unless specified

## Pneumatic Drive

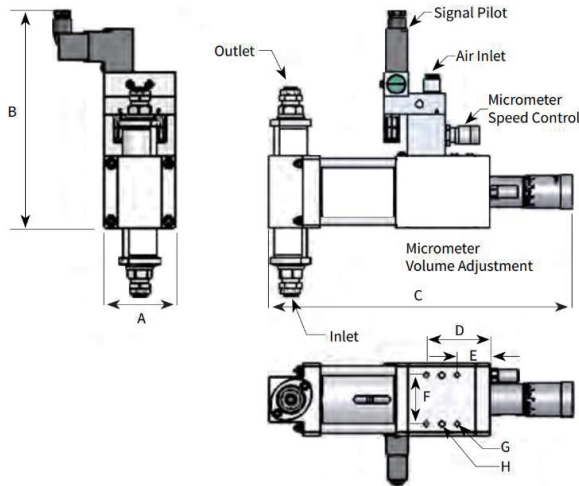

## Servo Drive

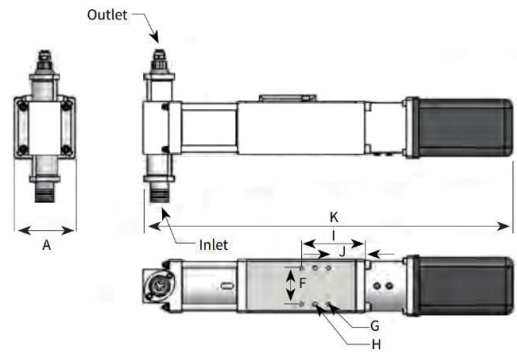

Model		External Dimensions Inch (mm)										
Pneumatic	Servo	A	B	C	D	E	F	G	H	I	J	K
4H1	4S1	2.95 (74.9)	8.92 (227)	11.47 (291.3)	2.60 (66.0)	1.35 (23)	2.00 (51)	M6 x 1.0  (7.9 Deep)	Ø 0.237 (6.0) ± 0.002 (0.05) x 0.03 (7.6) Deep	Servo Motor Dependent  Contact Your HIFE Rep	Servo Motor Dependent  Contact Your HIFE Rep	Coupler Dependent  Contact Your HIFE Rep
4H1 EX	4S1 EX			12.47 (316.7)								
4H2	4S2			15.44 (392.2)								
4H2 EX	4S2 EX			17.44 (443.0)								
4H3	4S3			19.44 (493.8)								
4H3 EX	4S3 EX			22.44 (570.0)								
4H4.5	4S4.5			21.24								



**HIFE SYSTEMS LTD.**

Aurora Canada    Heidenheim Germany    Sorocaba Brazil    Ningbo China

### Contact Us:

Asia: [sales@hife-battery.com](mailto:sales@hife-battery.com) – North America: [sales.1@hife-canada.com](mailto:sales.1@hife-canada.com)

Europe: [sales@hife-europe.com](mailto:sales@hife-europe.com) – South America: [sales@hife-brasil.com](mailto:sales@hife-brasil.com)